

HELIOS 56YW

Solar, Battery Powered White Floodlight



Helios Solar/Battery Powered Lights

Helios lights are designed for use with battery/solar powered systems. They are ideally suited for off-grid solar or mobile applications where 12-24V batteries are used. Helios lights are outdoor IP67 rated and are rugged and vandal resistant.

Easy Integration and Control

Helios lights have a built-in light sensor and can be set to turn ON/OFF depending on lighting conditions. Or, use the light's I/O ports to connect to a camera, sensors or other I/O port device to turn the light ON/OFF based upon pre-set conditions.

Lifetime Warranty - Made in the USA

AXTON Lights are covered by a lifetime warranty with advanced replacement.

FEATURES

- White Light - 9,500 lumens
- Outdoor IP67 Rated
- Energy Efficient - 56 Watts
- Advanced LED Technology
- I/O Port Sync with Sensors, Devices
- Automatic Day/Night Sensor
- Designed and Manufactured in the USA
- Lifetime Warranty

RANGE

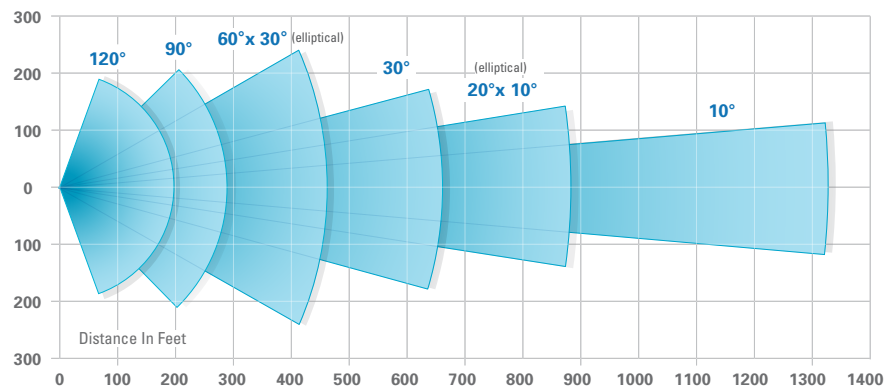

| | | | | | |
|--|---|---|--|--|---|
| Angle: 120° Range: 203'/62m HFOV: 352'/107m | Angle: 90° Range: 297'/90m HFOV: 382'/117m | Angle: 60°x 30° Range: 462'/140m HFOV: 462'/140m | Angle: 30° Range: 660'/201m HFOV: 341'/104m | Angle: 20°x 10° Range: 880'/268m HFOV: 275'/83m | Angle: 10° Range: 1,320'/402m HFOV: 230'/70m |
|--|---|---|--|--|---|

SPECIFICATIONS

| | |
|----------------------|---|
| White Light | Lumens: 9,500/ Temp: 5000K |
| Input Voltage | 9 to 28 VDC |
| Angle/Range Options: | 120°, 90°, 60°x30°, 30°, 20°x10° or 10° |
| Power Consumption | 56 Watts |
| Operating Temp. | -58° to 140°F / -50° to 60°C |
| Dimensions | 6.25" x 3.5" x 9.25"/ 159 x 89 x 235mm |
| Weight | 5.5 lbs / 2.5kg |
| Environmental | Outdoor IP67 Rated |
| Mounting | Pan/Tilt U Bracket Included |

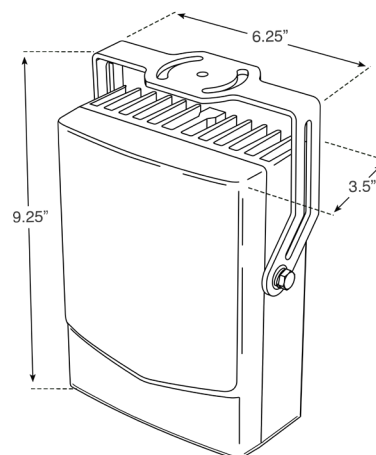

UNIVERSAL SOLUTIONS



801 Robinson Drive, Suite #500, North Salt Lake, UT 84054
Tel: 801/519-0500 • Email: sales@axtontech.com • Website: axtontech.com

