

Quick Setup Guide Hybrid PoE

AT-25HE-S | AT-56HE-S



WIRING

AXTON Illuminators have been designed and tested to run 24/7 continuously both indoors and outdoors.

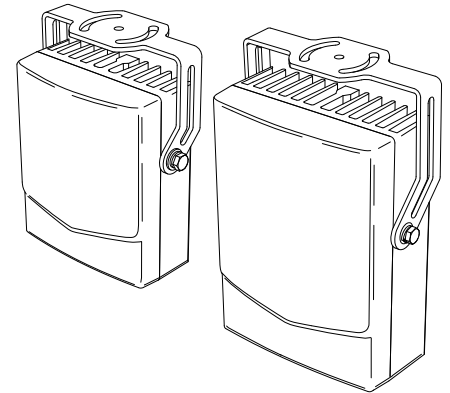
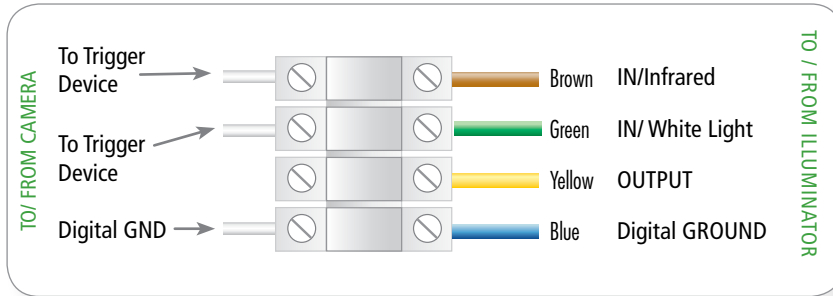

! Make all electrical connections **BEFORE** applying power.

PROGRAM YOUR CAMERA

You will need to log into the camera via computer and program the I/O ports to trigger when IR illumination is desired.

To switch illuminator Infrared ON, your camera Output port(s) have to be set as ACTIVE LOW. Status should be set to change in association with/during an event like IR cut filter, motion detection, etc.

To switch illuminator White Light ON, you will need a camera with a second output or an external triggering device such as a motion detector, door contact, etc. which will need to be set up the same as above (ACTIVE LOW).

Common Trigger Devices

Below are some examples of devices that can be used to trigger the illuminator's white light to switch ON during an event.



Camera



Door Contact



Motion Detector



Window Sensor

? QUESTIONS ? **(801) 519-0500** or **support@axtontech.com** | **axtontech.com**

POWER

Apply only the power specified below to the unit over the attached Ethernet cable.

P/N - WATTS	PoE TYPE
AT-25HE (25W)	PoE+ (802.3at) or PoE++
AT-56HE (56W)	PoE++ (802.3bt)



Applying voltage other than the required range may cause permanent damage and VOID WARRANTY

WARNING! Infrared light is not visible. Do not view directly with optical instruments (magnifiers) or stare directly into the illuminator at close distance.

Do not attempt to open or modify the light as this will void the warranty. If you need a modification, electric or physical, contact us directly. We will let you know if it can be done. All changes **MUST** be made at our factory.



801 Robinston Drive, Suite #500, North Salt Lake, UT 84054
☎ 801/519-0500 📠 801/519-0501 ✉ sales@axtontech.com

